



Year 2 Assessment Meeting

29th March 2023

Hassocks Infant School

★ Explore ★ Respect ★ Flourish



Do not panic!

- We do not want anybody worrying about these assessments. They are more our worry than yours!
- It is really important that the children do NOT know that they are taking tests. They will perform so much better without any worry/anxiety or stress.
- Their best is good enough. Our teacher assessments will count for more than the statutory assessments.



When, what and how?

- SATs will take place in May.
- They will be carried out in small groups or if appropriate 1:1 with an adult who the children are familiar with.
- They are **NOT** timed.
- There are 4 assessment papers in total.



Maths...

- Arithmetic Paper
 - 20 questions
 - Covers addition, subtraction, multiplication, division and fractions
- Reasoning Paper
 - Between 30/35 worded problem solving questions
 - Selection of questions covering all elements of the Year 2 mathematics curriculum
 - Questions can be read to the children if appropriate (except key mathematical vocabulary)
 - The paper starts off with 5 questions that are verbally read by an adult



Arithmetic Paper

13 $8 \times 10 =$

23 $65 +$ $= 93$

9 $8 + 5 + 4 =$

10 $36 + 24 =$

20 $86 - 21 =$

16 $12 \div 2 =$

25 $\frac{3}{4}$ of 40 =



Reasoning Paper

19 Amy buys an ice-cream for 90p.



(a) Tick (✓) **three** coins to show how Amy can make **90p**.





(b) Tick (✓) **four** coins to show another way to make **90p**.

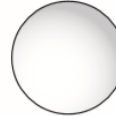
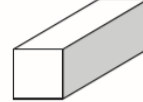
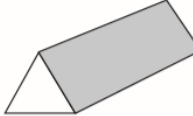

14 One shape is in the **wrong** place on the sorting grid.

Draw a cross (X) on it.

Shapes with a square face	Shapes without a square face
	
	
	

11 Use a ruler to measure the length of the toy car.

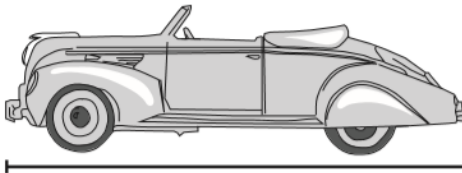

cm

22 Amy plants **4** rows of carrots.

There are **3** carrots in each row.

A rabbit eats **2** of the carrots.

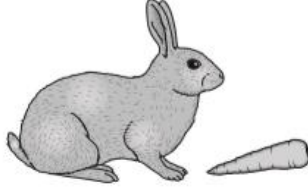

How many carrots are left?

Show your working

carrots

17 Sam is collecting cards.

He wants to collect **100** cards altogether.

Last week he collected **50** cards.

This week he collects **30** cards.



How many **more** cards does he need?

card



Reading...

- Reading Paper 1
 - 20 questions
 - 2/3 texts broken into short passages (fiction, non-fiction, poetry)
 - Retrieval, prediction, inference, sequencing
- Reading Paper 2
 - A reading booklet and answer booklet
 - Around 20 questions
 - Retrieval, prediction, inference, sequencing



Reading Paper 1

9 Find and copy one word which tells you that Monster was not feeling well in the boat.

12 How do you know that Frog was excited?

20 Number the sentences below from 1 to 4 to show the order they happen in the story.

The first one has been done for you.

They found a big basket.

They fell asleep on an island.

They went in a boat.

The boat drifted away from them.

10 Frog spotted something on the water.

What does the word *spotted* mean in this sentence?

Tick **one**.

smelt

heard

felt

saw

15 How can you tell that it was late when Monster and Frog woke up?



Reading Paper 2

(page 6)

6 The blackbird said: "You and I are at war."

How do you know that the king was **not** worried by this?

(page 7)

8 Find and copy **two** words that describe how scared the king was.

1. _____
2. _____

10 Tick **two** good points about plastics.

Plastics can be...

nice to smell.

any shape.

grown.

eaten.

many colours.

Tick **two**.

5 For years he's drained me and dirtied me.

What does the word *drained* mean?

Tick **one**.

filled up with water

stirred up the water

emptied out the water

worn out the water

18 Put ticks in the table to show which sentences are **true** and which are **false**.

One has been done for you.

The information says that...	True	False
recycling is a good way to get rid of unwanted plastics.	✓	
we should use more things made of plastic.		
today we use plastics a lot.		
plastic is hard to get rid of.		
plastics rot.		

Putting ourselves in their shoes...

- How many of these do you think you know?:
 - A verb...
 - A noun...
 - An adjective...
 - An adverb...
 - A root word...
 - A contraction...
 - A suffix...
 - A prefix...
 - A homophone...
 - A pronoun...



How can you help at home?

- Apps/Websites:

- Whiterose Maths 1 minute maths
- Numberblocks
- Hit the Button
- Using Purple Mash to play games and activities

- In the car:

- Number bonds to 10/20/100
- Counting in 2s, 5s, 10s, 3s
- 10 more/less
- Naming and recognising 2D and 3D shapes in the environment

- At home...

- Reading - Use the guidance in the green books to ask additional questions about the text. Little Wandle books have comprehension questions at the back to support your child's reading.
- Maths – Use the parent overview each week to talk to your child about their maths learning and practise at home. When Maths home learning is set eg on Purple Mash as a follow up to our learning in class, please encourage and support your child to do this at home.
- Practise reading the time on an analogue clock, recognising coins and notes, ordering the days of the week and the months of the year.
- Spelling - Practise the weekly spellings and go back through previous weeks' spellings too.
- Grammar – charades or hangman with a noun/verb/adjective/adverb focus
- CGP SATs workbooks.

Please remember NOT to mention SATs to your child – they do not need to know!

We call them special quizzes or booklets and make them fun!

Don't panic or stress, they will all be absolutely AMAZING!

